

# Moyeu expansible EN INOX Série WSR 250 R

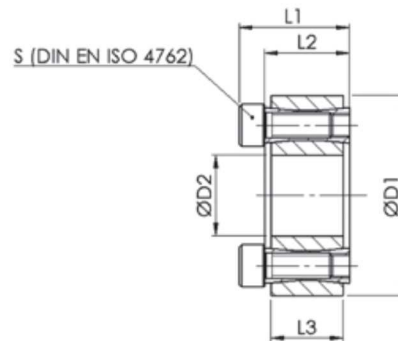

Référence de commande

**WSR 250 - R - 42 x 75**  
Type  $\varnothing D2 \times \varnothing D1$

## Caractéristiques techniques et dimensionnelles

$\varnothing$ int D2 x $\varnothing$ ext D1	Couple $T_{KN}$ Nm	Dimensions (mm)			Pression de surface de contact entre moyeu expansible et...		Vis de serrage		
		L1	L2	L3	arbre $P_W$ N/mm <sup>2</sup>	moyeu $P_N$ N/mm <sup>2</sup>	S	Vis	couple de serrage
							Qté	DIN EN ISO 4762	$T_A$ (Nm)
20 x 47	110	26	20	17	133	57	8	M6	8
22 x 47	120	26	20	17	121	57	8	M6	8
24 x 50	150	26	20	17	125	60	9	M6	8
25 x 50	155	26	20	17	120	60	9	M6	8
28 x 55	170	26	20	17	107	55	9	M6	8
30 x 55	185	26	20	17	100	55	9	M6	8
32 x 60	265	26	20	17	125	66	12	M6	8
35 x 60	290	26	20	17	114	67	12	M6	8
38 x 65	390	26	20	17	131	77	15	M6	8
40 x 65	410	26	20	17	125	77	15	M6	8
42 x 75	595	32	24	20	138	78	12	M8	18
45 x 75	635	32	24	20	129	78	12	M8	18
48 x 80	680	32	24	20	121	73	12	M8	18
50 x 80	700	32	24	20	116	73	12	M8	18
55 x 85	905	32	24	20	123	80	14	M8	18
60 x 90	990	32	24	20	113	76	14	M8	18
65 x 95	1225	32	24	20	119	82	16	M8	18
70 x 110	1875	38	28	24	131	84	14	M10	35
75 x 115	2010	38	28	24	123	80	14	M10	35
80 x 120	2145	38	28	24	115	77	14	M10	35
85 x 125	2600	38	28	24	124	84	16	M10	35
90 x 130	2750	38	28	24	118	81	16	M10	35
95 x 135	3280	38	28	24	125	88	18	M10	35
100 x 145	3870	45	33	26	121	84	14	M12	60

Tolérances conseillées : Arbre h8  
Moyeu H8

Autres tailles sur demande

**A.C.C.&S.** SAS

57 rue de la Grossau - F-67100 STRASBOURG  
tél : +33 [0]3 88 55 94 94 / fax : +33 [0]3 88 55 94 95  
infos@acces.ac / www.acces.ac